

ITEM NO.	PART NUMBER	DESCRIPTION	QTY
1	3-897-10090	MOUNTING BOLT, 10x1.5, 90mm	3
2	3-891-606P	FULL OEM JAW REPLACEMENT SET, 6IN, 6-JAW	6
3	3-889-008P	WRENCH FOR 6IN & 8IN SCROLL CHUCK	1
4	3-886-306P	PINION FOR 6IN SCROLL CHUCK	3
5	C-CK6-BDY6JFM	CHUCK BODY, 6IN	1
6	3-809-906P	FITTING, GREASE	1
7	3-887-306P	SCROLL PLATE FOR 6IN CHUCK	1
8	3-888-906P	PINION SCREW FOR 5IN&6IN CHUCK	3
9	C-CK6-COVER	PLATE, COVER, MACHINED	1
10	3-899-310P	SHCS, M8x1.25X16	3
11	3-897-606P	FINE ADJUSTMENT SCREW, M18x1 FOR 6in SET-TRU	4
12	C-CK6-MODULE	MODULE, SET-TRU, 6IN	1
13	3-897-10030	MOUNTING BOLT, 10x1.5, 30mm	3

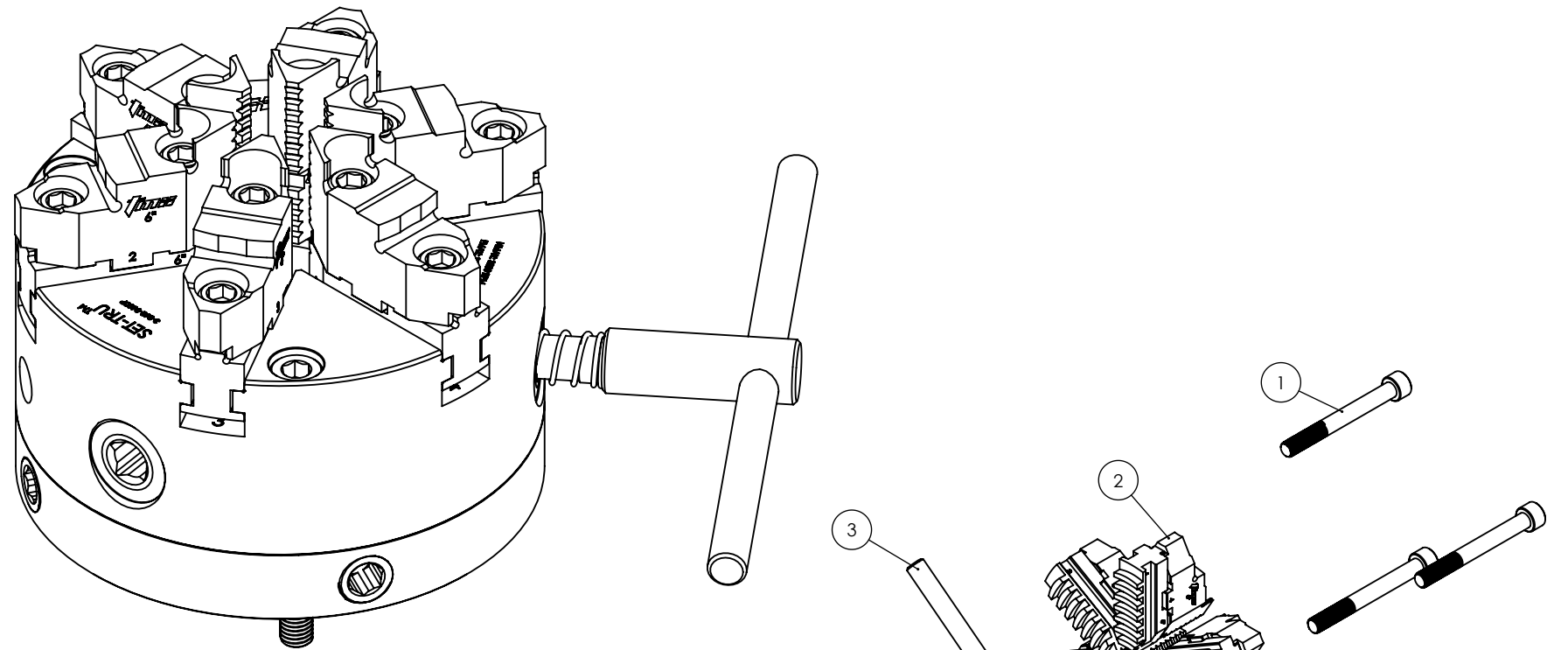

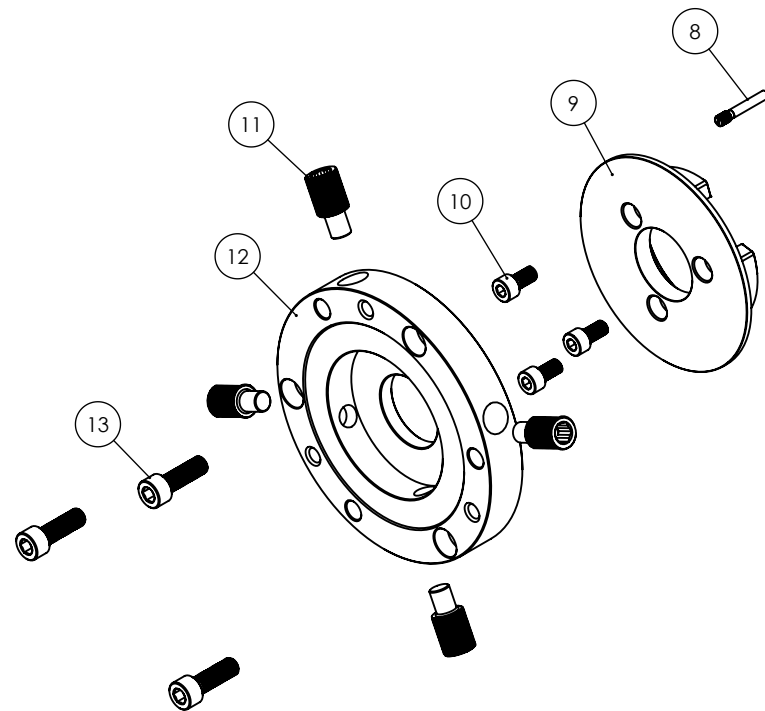

-CLICK ON LINK BELOW FOR REPLACEMENT PARTS-

[WWW.TOOLMEX.COM](http://WWW.TOOLMEX.COM)



SELLING UNIT: EACH  
 CHUCK TYPE: SCROLL  
 CHUCK SIZE: 6IN  
 BODY MATERIAL: FORGED STEEL  
 NUMBER OF JAWS: 6  
 JAW TYPE: 2 PIECES  
 WEIGHT: 29 LBS  
 MOUNT TYPE: FRONT  
 GRIPPING FORCE: 3100 daN  
 SPEED: 3200 RPM Max.

MATERIAL:	SEE BOM	NAME	DATE	 <b>TOOLMEX™</b> SOLE PROPERTY OF TOOLMEX INDUSTRIAL SOLUTIONS	
HARDNESS:	N/A	FINISH:	N/A		
CONTACT INFORMATION: Toll Free 855-869-2425 Fax 508-653-5110 www.tmxtools.com 34 TALBOT ROAD NORTH BOROUGH, MA 01532 USA		DRAWN	T. THACH		10-28-2024
INTERPRET GEOMETRIC TOLERANCING PER: Y1999-2001		ENG APPR.	T. THACH		10-28-2024
 THIRD ANGLE PROJECTION		MFG APPR.			
		Q.A. APPR.			
		SALES APPR.			
		CONFIDENTIAL THIS DRAWING AND THESE SPECIFICATIONS ARE THE SOLE PROPERTY OF TOOLMEX INDUSTRIAL SOLUTIONS, AND SHALL NOT BE REPRODUCED, OR COPIED IN PART OR AS A WHOLE WITHOUT THE EXPRESS WRITTEN PERMISSION OF TOOLMEX INDUSTRIAL SOLUTIONS IS PROHIBITED.		TITLE <b>6IN, 6-JAW PLAIN BACK FRONT          MOUNT SET-TRU SCROLL CHUCK</b>	
		SIZE	DWG. NO.	REV	
		<b>B</b>	<b>3-868-0600P</b>	<b>A</b>	
		UNITS IN MILLIMETER			
		DO NOT SCALE DRAWING		SHEET 1 OF 3	

8 7 6 5 4 3 2 1

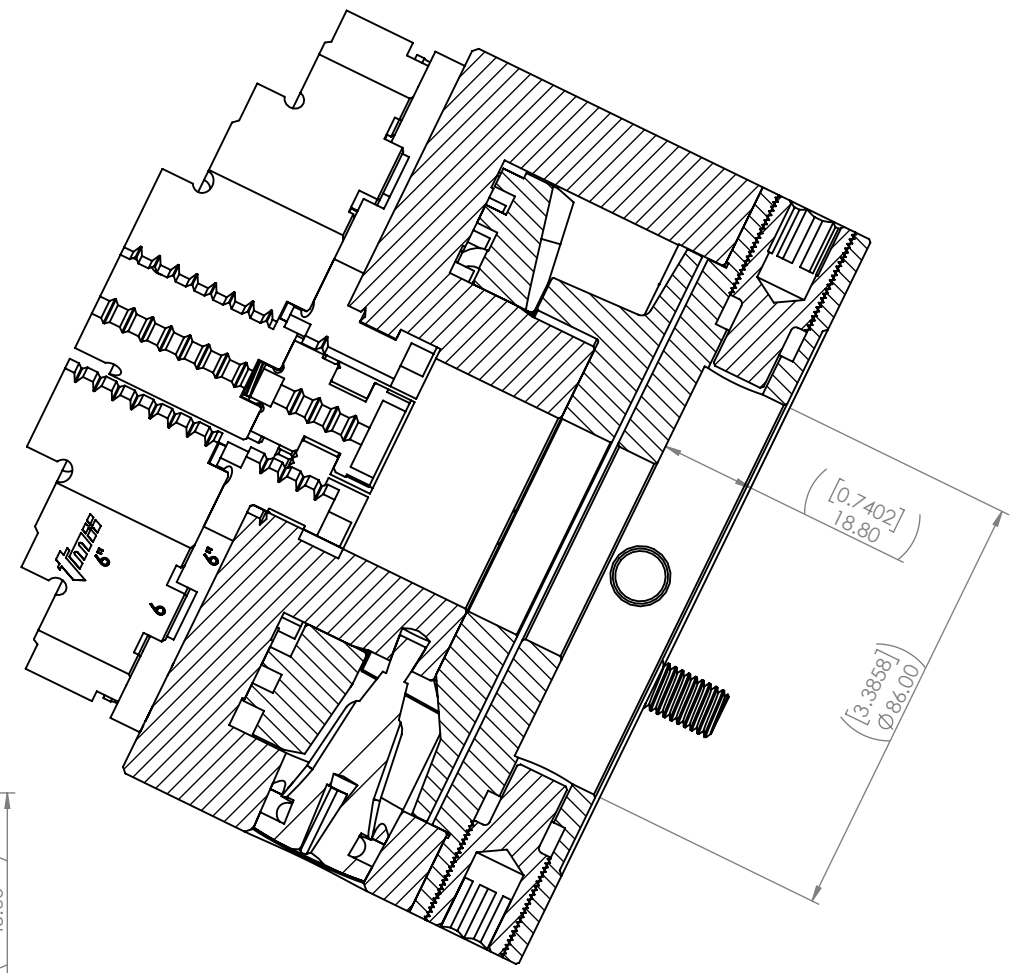
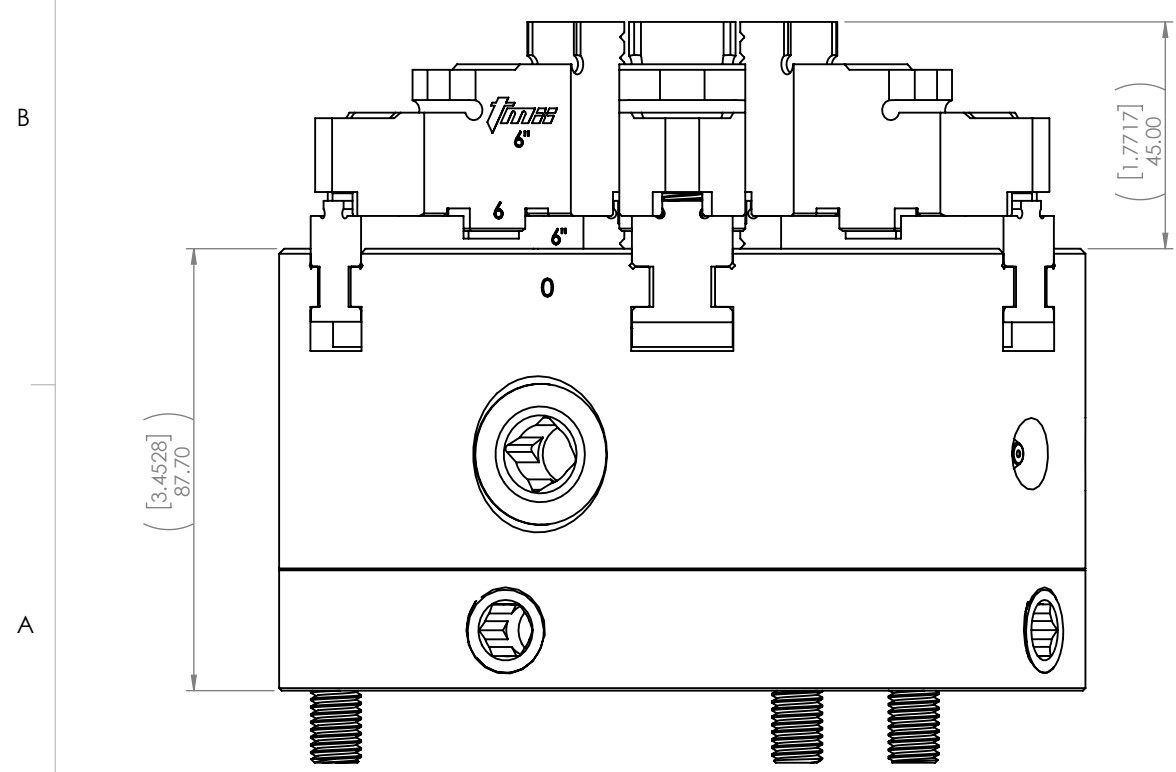
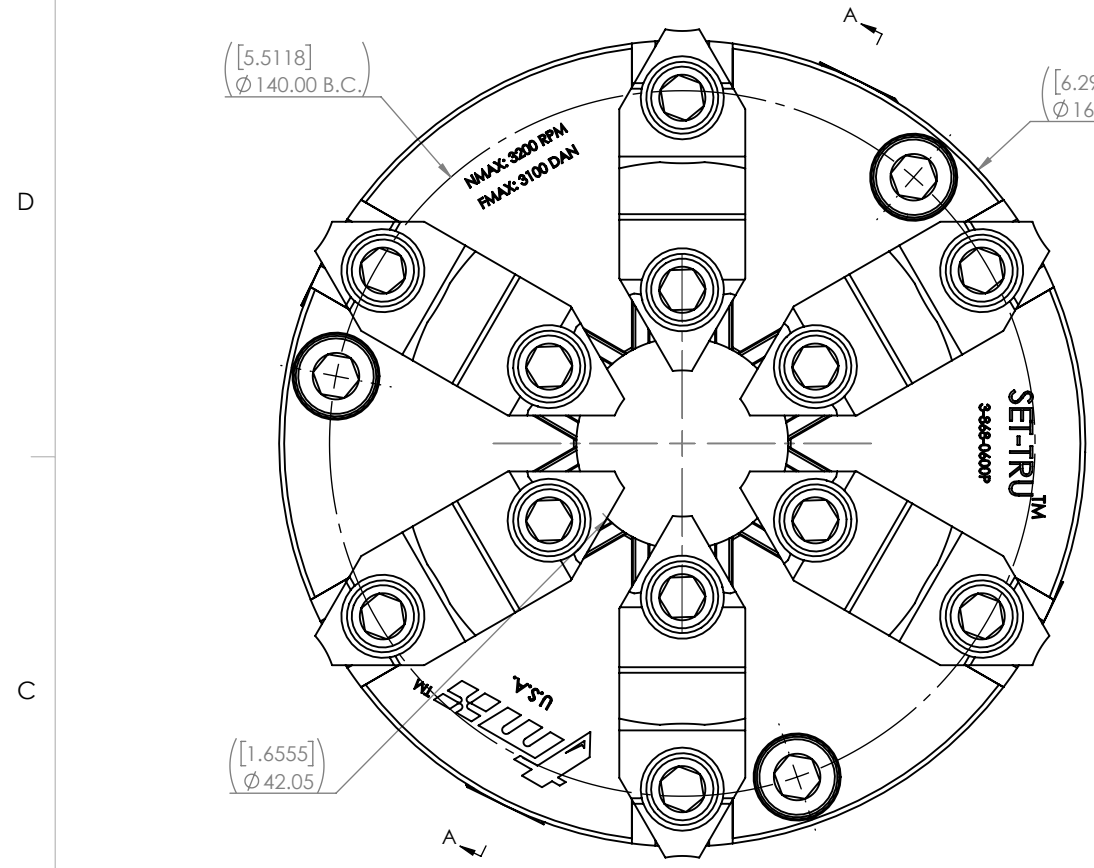

SECTION A-A

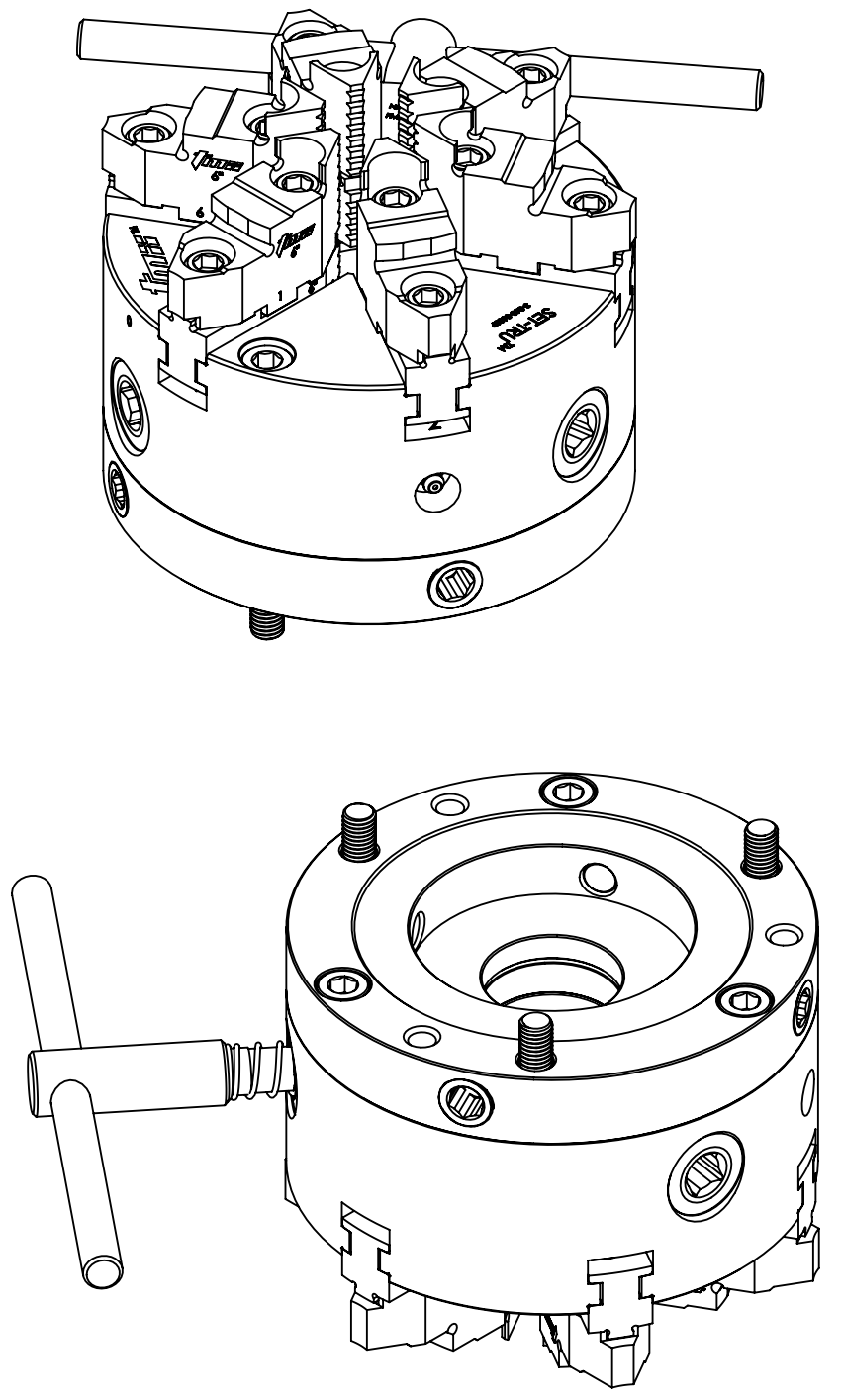

MATERIAL:	SEE BOM	NAME:	T. THACH	DATE:	10-28-2024	
HARDNESS:	N/A	FINISH:	N/A	DRAWN:	T. THACH	
<p><b>CONTACT INFORMATION:</b>                  Toll Free 855-869-2425                  Fax 508-653-5110                  www.tmxtools.com                  34 TALBOT ROAD                  NORTH BOROUGH, MA 01532 USA</p>			ENG APPR.:	T. THACH	10-28-2024	
<p>INTERPRET GEOMETRIC                  TOLERANCING PER: Y1999-2001</p>			MFG APPR.:			
<p>THIRD ANGLE PROJECTION</p>			Q.A. APPR.:			
<p>CONFIDENTIAL                  THIS DRAWING AND THESE SPECIFICATIONS                  ARE THE SOLE PROPERTY OF TOOLMEX                  INDUSTRIAL SOLUTIONS, AND SHALL NOT BE                  REPRODUCED, OR COPIED IN PART OR AS A                  WHOLE WITHOUT THE EXPRESS WRITTEN                  PERMISSION OF TOOLMEX INDUSTRIAL                  SOLUTIONS IS PROHIBITED.</p>			SALES APPR.:			
<p><b>TOOLMEX™</b> SOLE PROPERTY OF                  TOOLMEX INDUSTRIAL SOLUTIONS</p>					TITLE	6IN, 6-JAW PLAIN BACK FRONT MOUNT SET-TRU SCROLL CHUCK
<p>SIZE DWG. NO.</p>					REV	A
<p><b>B</b> 3-868-0600P</p>					<p>UNITS IN MILLIMETER</p>	
<p>DO NOT SCALE DRAWING</p>					<p>SHEET 2 OF 3</p>	

8 7 6 5 4 3 2 1

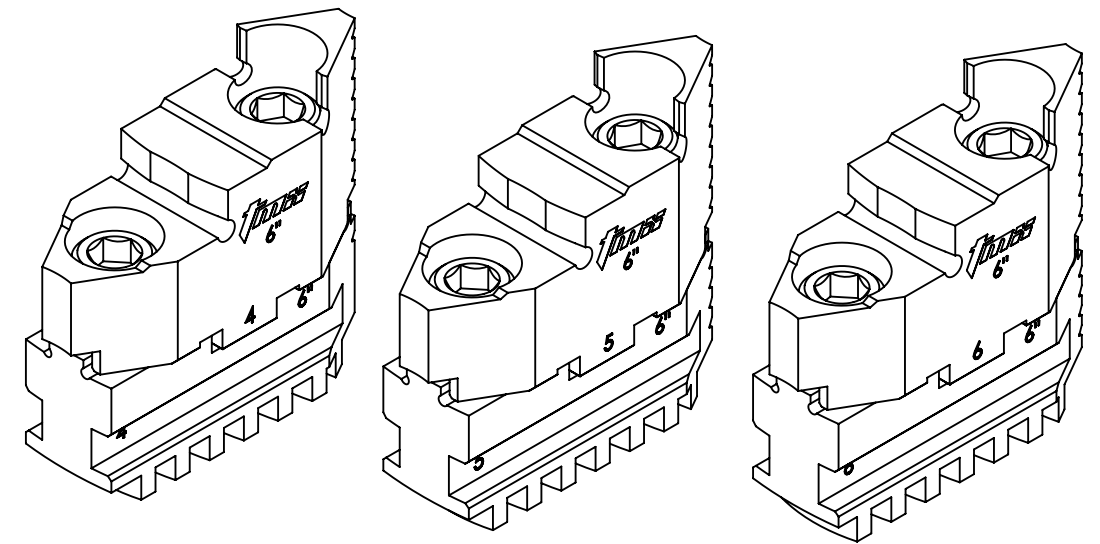
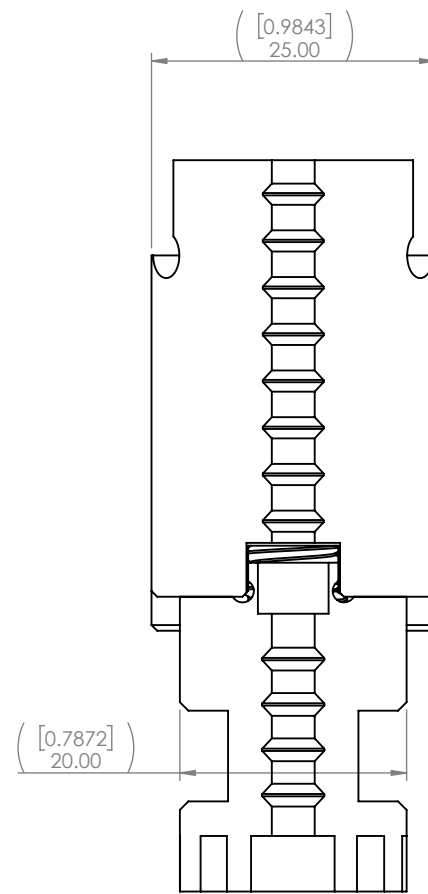
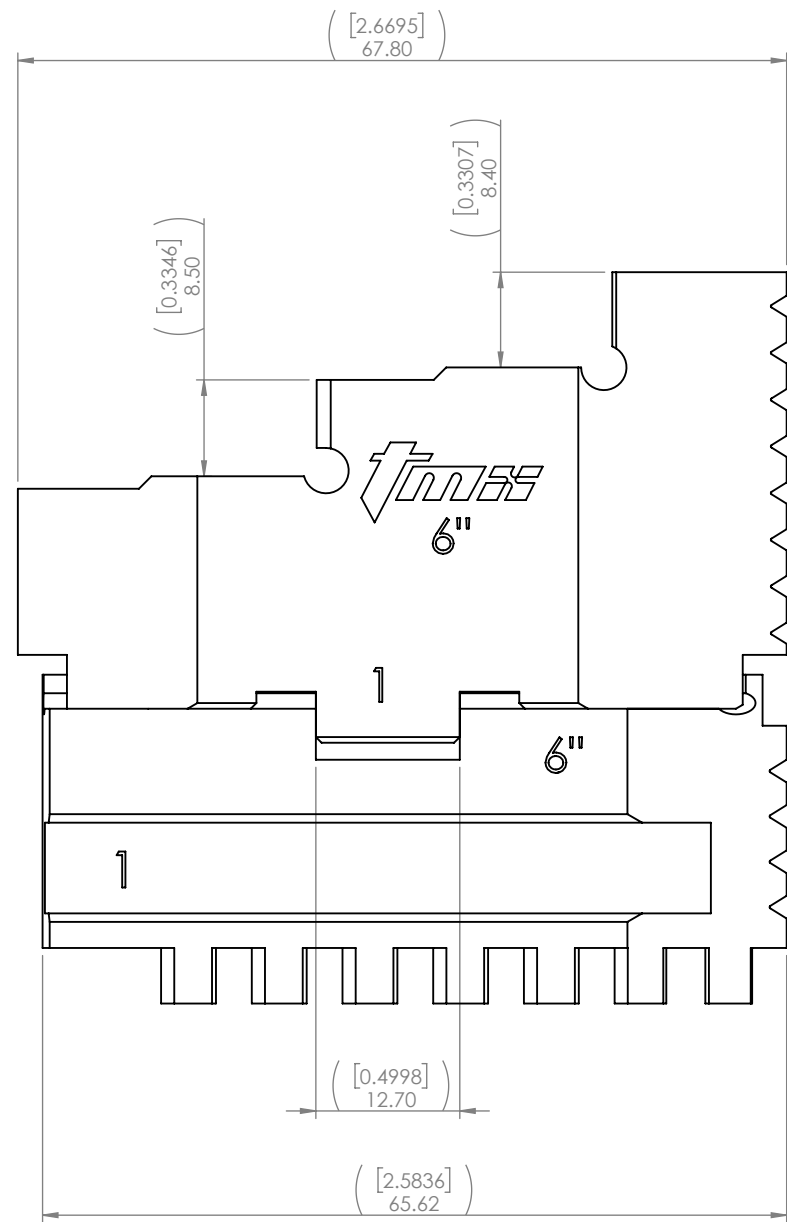
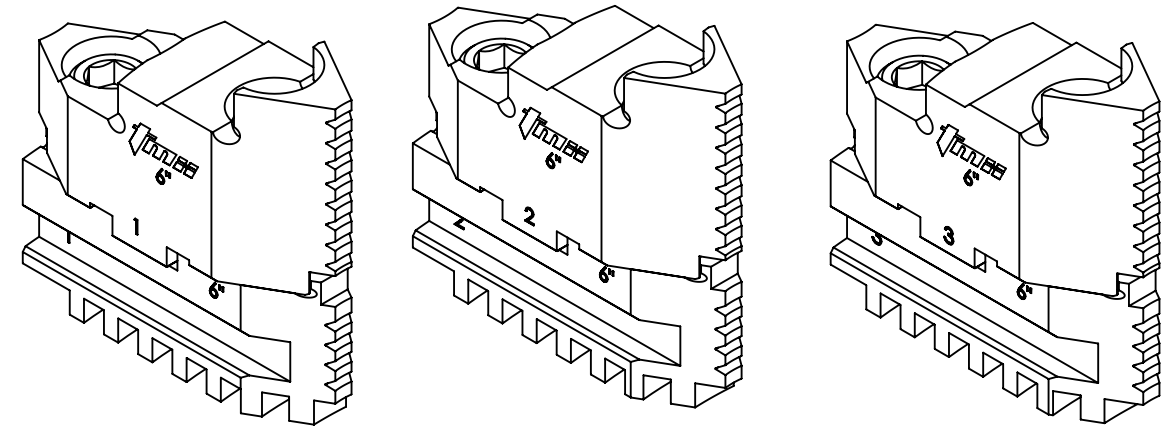
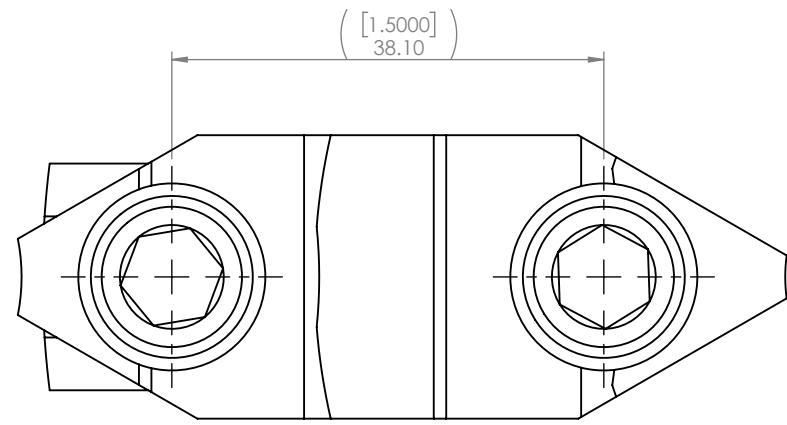

**-CLICK ON LINKS BELOW FOR REPLACEMENT PARTS-**

**3-883-606P, HARD TOP JAWS, 6IN, 6-JAW 6 PC SET**

**3-885-606P, HARD MASTER JAWS, 6IN, 6-JAW 6 PC SET**

MATERIAL:	SEE BOM	NAME	T. THACH	DATE	10-28-2024
HARDNESS:	N/A	FINISH:	N/A	DRAWN	T. THACH
<p><b>CONTACT INFORMATION:</b>            Toll Free 855-869-2425            Fax 508-653-5110            www.tmxtools.com            34 TALBOT ROAD            NORTH BOROUGH, MA 01532 USA</p>			ENG APPR.	T. THACH	10-28-2024
			MFG APPR.		
			Q.A. APPR.		
			SALES APPR.		
<p>INTERPRET GEOMETRIC TOLERANCING PER: Y1999-2001</p>			<p><b>CONFIDENTIAL</b>            THIS DRAWING AND THESE SPECIFICATIONS ARE THE SOLE PROPERTY OF TOOLMEX INDUSTRIAL SOLUTIONS, AND SHALL NOT BE REPRODUCED, OR COPIED IN PART OR AS A WHOLE WITHOUT THE EXPRESS WRITTEN PERMISSION OF TOOLMEX INDUSTRIAL SOLUTIONS IS PROHIBITED.</p>		
<p>THIRD ANGLE PROJECTION</p>			<p><b>TOOLMEX</b>™ SOLE PROPERTY OF TOOLMEX INDUSTRIAL SOLUTIONS</p>		
			<p>TITLE 6IN, 6-JAW PLAIN BACK FRONT MOUNT SET-TRU SCROLL CHUCK</p>		
			SIZE	DWG. NO.	REV
			<b>B</b>	<b>3-868-0600P</b>	<b>A</b>
			UNITS IN MILLIMETER		
			DO NOT SCALE DRAWING		SHEET 3 OF 3